

*Eagle*

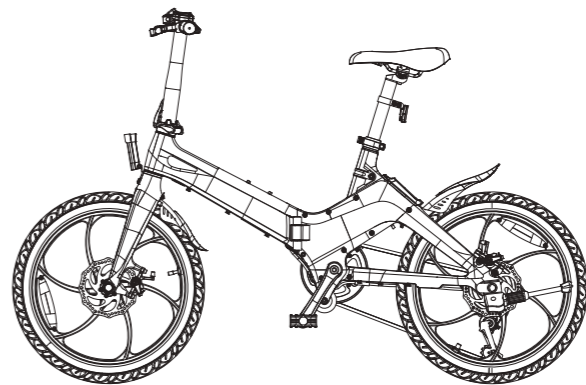

User Guide

ONEBOT Electric Folding Bike *Eagle*

## Read First

Thank you for choosing ONEBOT E-BIKE (Model: Eagle)  
Please read this entire user manual carefully when first use,  
includes safety notes and correct instructions.

This manual will help you

- 1) Understand the basic operating steps and how to use the control panel;
- 2) Familiar with riding principles, makes you ride safety and happy;
- 3) Understand the product structure and how it works, learn the daily maintenance methods to extend product life

# Warranty Policy

## Coverage

Warranty Content	Warranty Validity	Remarks
Battery	12 months	Battery leaked and plastic case cracked under normal use, capacity is less than 60% of the rated capacity after tested.
Motor	12 months	Gear breakage, broken bearing, cracked casing, burned, etc. (Man-caused damage excluded).
Charger	12 months	Appearance no cracks, unopened and label no destroyed;
Meter	12 months	Any malfunction while the appearance is not damaged and wires are all connected well.
Controller	12 months	Performance failure within one year. (Must be unopened)
Crank and chain wheel, front fork/axle, freewheel, chain & belt	6 months	Free repairing within 6 months, man-caused damage excluded.
Brake lever, throttle & sensor	3 months	Any malfunction while the appearance is not damaged and wires are all connected well.
Saddle, battery shell & base, paint damage in large area	3 months	Man-caused damage excluded.
Lighting, pedals, tires, handlebars	1 months	Man-caused damage excluded.

### Notes:

1. Disassemble without permission, external collision, man-made damages are not under warranty.
  2. Consumables parts (brake pads, brake wires, tires and tubes, mudguards and other plastic parts) are not covered in the warranty.
  3. Repairing of man-caused damages or beyond warranty time will be charged accordingly.
- Warranty validity: from the date of shipping.

# Packing List

Bike Frame Body

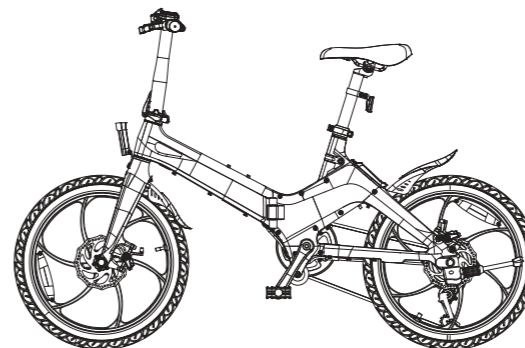

Seat Post

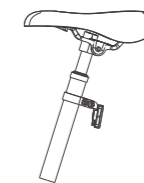

Charger

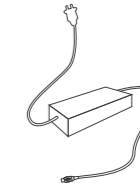

User Informations

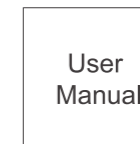

## Initial Use

Suggest to wear the helmet and gear for safety when first use, and riding in open spaces.  
 Pay attention: This E-bike is only designed for city road, forbidden riding under non-urban road environment.

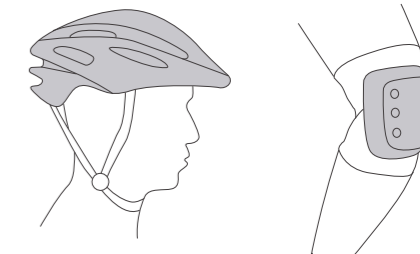

# Storage and Maintenance

1. Keep the e bike in a place where there is no direct sunlight or no rain after riding.
  2. Regularly check each screw of the e bike and to be tightened, and tighten it regularly;  
(Screw torque of each main position: the head tube screw: 180-220kgf.cm;  
Saddle screw: 180-220kgf.cm; front wheel nut: 250-300kgf.cm; rear wheel nut: 300-350kgf.cm)
  - 3.If there is stain on the surface of the e bike body, use a soft cloth to wipe by a small amount of water; do not use alcohol, gasoline or other chemical solvents with corrosive and volatile, otherwise it will seriously damage the appearance or internal structure of the e bike body.
  - 4.Chain elastic standard: chain up and down ≤ 10mm; if the chain is loose, the rear wheel nut can be loosened, the chain tensioner can be adjusted to the chain fastening state, and the rear wheel nut can be tightened.
  - 5.If the disc brakes and the disc plate friction, adjusting the position to make them no interference friction.  
If the disc plate skew heavy or the disc brake is disabled, then the disc or disc brake needs to be replaced.
  - 6.Every 3 months, apply grease to the frame folding wrench screws and maintain the chain smear chain anti-rust oil.
  7. If the shock absorber fails or is damaged, it is necessary to disassemble the original shock absorber and replace a new shock absorber to achieve the best shock absorption effect.
- Do not flush the e bike with water to avoid accidents caused by internal electronic components and wiring.

## Regular maintenance & check

Maintenance part	Maintenance purpose
Brake	Check the brake function, prevent accidents caused by brake dysfunction
Tire	Check the tires condition and pressure, in case tires bursting or over power consumption during riding
Tire Rim	Check the rim conditions, clean dirt, in case rim breaks or get stuck
Shock absorber	Check the shock absorber condition, clean and lubricant, keep it in a good working condition
Throttle	Check throttle condition, in case dysfunction or malfunction
Wires	Check if the wires ports are loose or broken in case of wiring faulty
Screws	Check the screws in the main parts, in case they get loose or fall off
Battery	Check the appearance and the battery performance, in case of wiring faulty, extend the lifespan of the battery
Charger	Check if the charger cable are impact, input and output plug are reliable
Lubrication	Check if the axles and brake lights need lubrication or not
Cleaning	Keep the bike surface in a clean condition

Tip: Please maintain and check the e bike regularly, to keep it in a best riding condition.

## 2.Unfold the stem

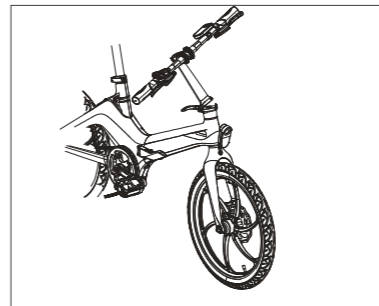

1. Hold the bike body and turn the stem upright to ensure that the stem is seamlessly connected to the underside

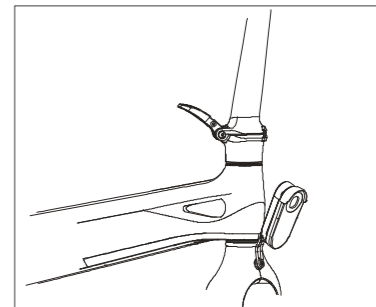

2. Fasten the folding wrench directly in the direction of the stem

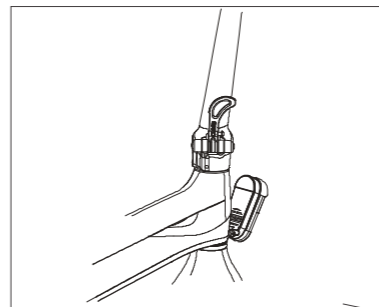

3. Slightly shake the stem and check if the security buckle is fully buckled..

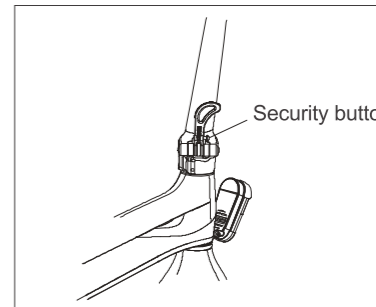

4. When folding the stem, you need to press the security buckle and then open the folding wrench to it

## Matters need attention

1 Please take the initiative to understand and comply with local traffic regulations before riding.

2 In case of accidents and injury, you should wear protective appliances well before riding, like helmet, gloves, elbow pads, knee pads etc.

3 You should check your bike conditions before riding. (make sure that brakes work well, battery is fully charged, enough tire pressure, no abnormal sound, no screws loosen etc)

4 Do not ride on slippery road conditions, especially on snowy and watery roads.

5 Do not ride on slopes over 15°.

6 If you must ride when it's raining or snowing, keep it at a low speed and a longer distance from the vehicles in front of you, in case of emergency stops.

7 Kids under age 12 are not allowed to ride the e-bike.

8 Avoid sudden acceleration and deceleration, do not exaggerated lean, either forwards or back while riding, and keep it at a limited speed.

9 When the remaining battery power is low, please ride on low constant speed and charge the battery as soon as possible.

10 If a fall is inevitable, always keep your safety prior to the bike.

11 Do not put your hands in pocket while riding in case of emergency.

12 Do not store your bike in car trunk too long time in hot weather.

13 Please study the local traffic laws and regulations before riding, keep civilized riding

14 Keep an eye on the surroundings, ride in a controllable condition and avoid any collisions that might occur.

15 Keep a safe distance from others while riding, and do not ride neck by neck on the road.

16 Do not ride in dim environments, if necessary, be cautious and lower your speed or stroll your bike.

17 Do not ride backwards and do not do any actions that might endanger yourself or others while riding.

18 Do not lend your bike to those who are not familiar with the manual.

19 Do not ride while you don't feel well, nor after taking drugs or consuming alcohol.

20 Do not lift your bike from tires, to avoid that your fingers get stuck between the tire and the casing.

21 Please speed up slowly. Sudden acceleration may cause out-of-balance and injure yourself.

22 Do check the brake function before riding, regularly adjust the brake wire tension

23 The Power Assist Sensor (PAS) will start to work when pedaling 3/4~1 cycle. Beware of crank rotating when walk.

24 Brake lever control is left for front brake, right for rear brake

## 6. Unfold & Fold the pedals

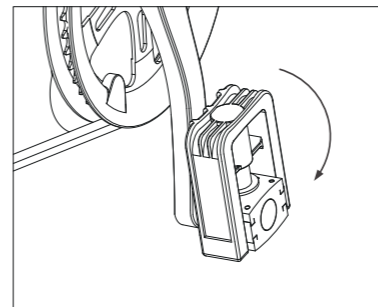

1. Hold the vehicle body and unfold the pedals

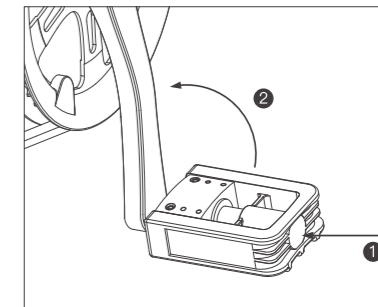

2. Press the pedal towards the crank, and fold it up.

## 7. Power on operation

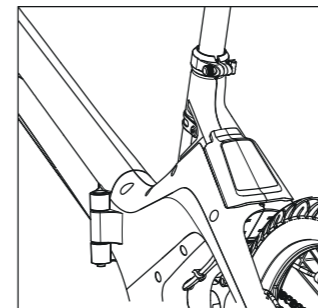

1. Charge the battery before your first ride.  
Note: When charging is completed, please cover the plug to avoid the water intake of the charging port.

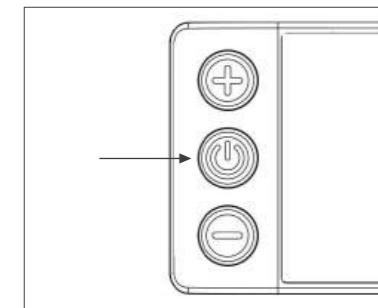

2. Press  button for 3 seconds to boot

# Parameters

Mechanical configuration	Color options	Subject to the actual product	Battery	Battery installment	Built-in/ Lock/Removable
	Unfold size	1520*650*1080mm		Battery capacity	36V 10.2Ah
	Fold size	800*430*670mm		Battery type	Samsung Li-ion power battery
	Seat height	800-860 adjustment		Battery weight	1.8kg
	Wheel base	1000mm		Charging current	Max 2A
	Net weight (excl. battery)	18kg		Charging hour	3-5 hours
	Brake system	Front and rear disc brake		Power consumption per charge	0.3KWH
	Tire Dimension (Inch)	20x2.125 inch		Battery lifespan	Over 800 times
	Frame material	Integrated magnesium alloy frame		Charging temperature	0°C-45°C
	Suspension system	N/A		Charger	Rated input
Max speed	25km/h	Rated output	42V 1.5A		
Function parameters	Max mileage	45km	Meter	Display	Full perspective LCD display
	Max load	120kg		Remaining power	Yes
	Climbing angle	<15°	Speed	Yes	
	Lighting	Front LED light	Total mileage	Yes	
	Braking length (dry condition)	5m (speed at 20km/h)	Speed mode	3 modes	
	Braking length (wet condition)	10m (speed at 15km/h)	Motor	Voltage/Power	36V/250W
	Driven mode	EPAC		Rated Torque	10.8Nm
	Working temperature	-10°C-50°C		Waterproof level	IPX4

### Remarks:

- 1.Mileage is subjected to weight, road condition, temperature, wind speed, riding habit ect. conditions, and the mileage on the UM is tested under the condition of loading 65kg, 25 C temperature, riding on flat road, wind less than 10Km/h with full electric.
- 2,Pls use original charger to charging the bike/battery.
- 3.Pls don't modify the bike without authorization.

# Other Operations

## Uninstall&Install battery

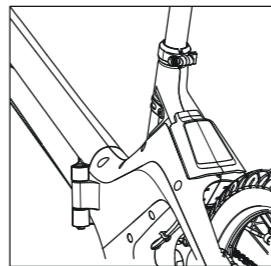

- 1.Power off the vehicle, unlock the battery, then pull out the battery box with the lifting handle as picture shows.

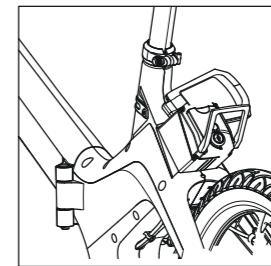

- 2.When installing battery, lock the battery with key and take the key away, press battery handle to be flat, and unfold the bike frame.

# Components

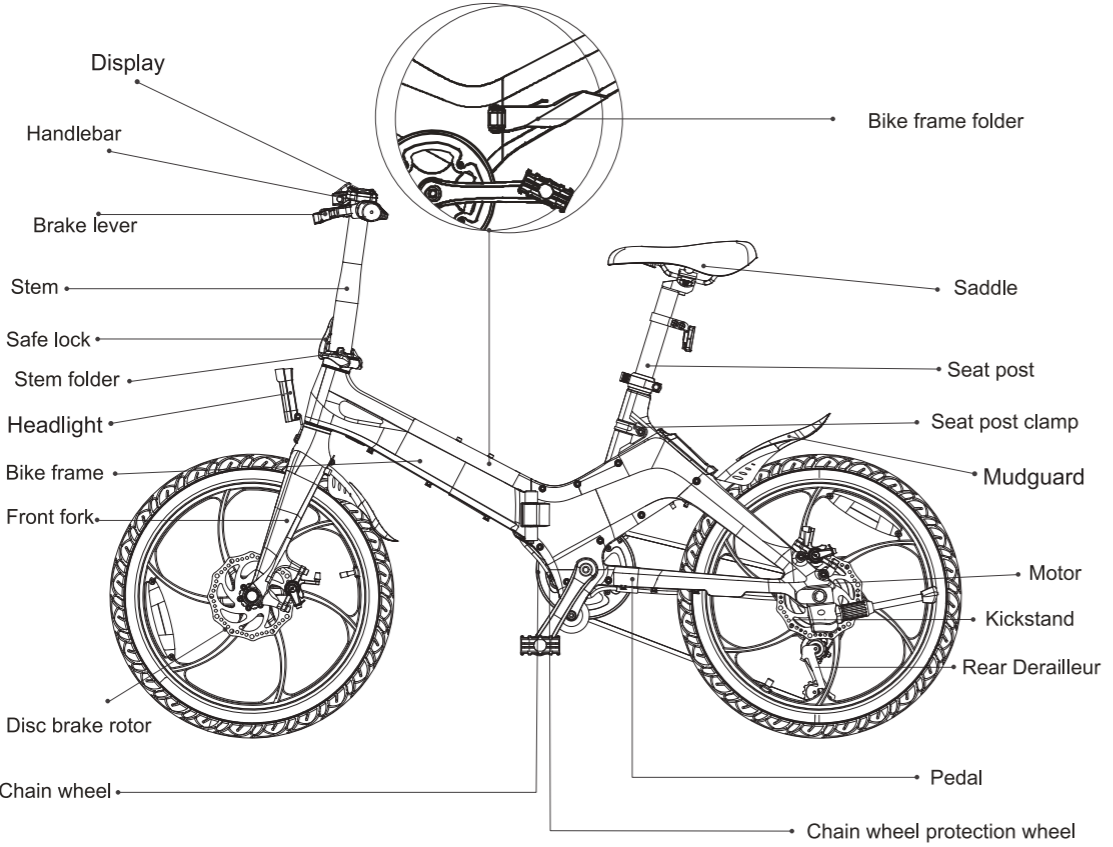

# Quick Start

1.Unfold the bike

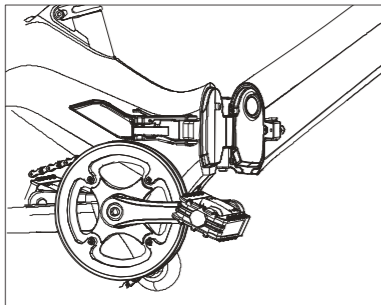

1.Hold the vehicle body, unfold the frame

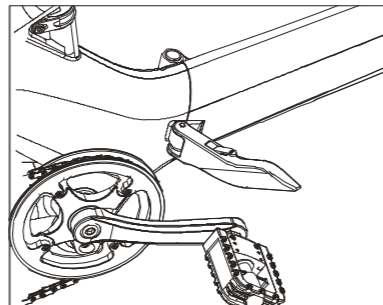

2.As picture, lock the folder clamp tightly, please finish step 3) & 4) before lock the clamp

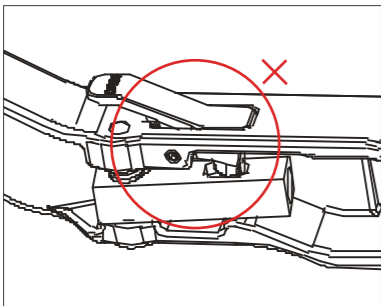

3.If the fastener shows as picture, need press it down to release the convex piece

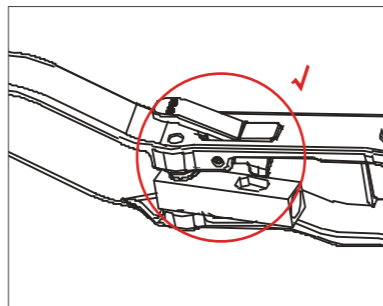

4.If the fastener shows as picture, then can operate step 2) to lock the frame

# Eliminate of frequent malfunction

No power assist after power on	vehicle no electric	1.check to ensure the battery mount well 2.Low voltage of battery, need charge the battery
Shortage of mileage	1.Low power of battery 2.Low pressure of tire 3.Continually braking, power on/ off and overload riding 4.Aging or normal recession of battery 5.Environment temperature is too low, battery recession easily	1.Check to ensure the charger function well 2.Check the tire pressure before use 3.Keep good riding habit 4.Change battery 5.Belong to normal phenomenon
Disable charge of battery	1.Charger plug do not plug well 2.Battery temperature is too low 3.Battery temperature is too high	1.Check charger plug loose or not 2.Wait till the temperature recover to charging temp. 3.Wait till the temperature recover to charging temp.
No data display on meter	1.Vehicle no power 2.Power transverter damage 3.Meter malfunction	1.Check battery to ensure it mounts well; battery low voltage, charge battery 2、 3. Contact AFS department, change defective parts
Motor cannot start when power on and turn the throttle	1.On status of braking 2.Meter "M" button malfunction	1.Check to ensure the it's not on braking status 2.Contact AFS department, check the display

## 4. Seat post assembling

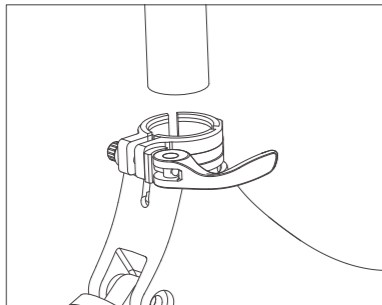

1. Loosen the seat post clamp, keep the bike steady, insert the seat post in the frame.

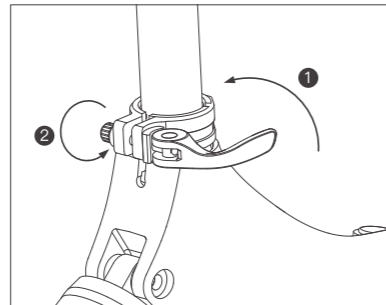

2. Adjust the screw, tighten the clamp, then press the saddle at full tilt to ensure the seat post locked tight enough and doesn't rotate or move up and down.

## 5. Adjustment of saddle height

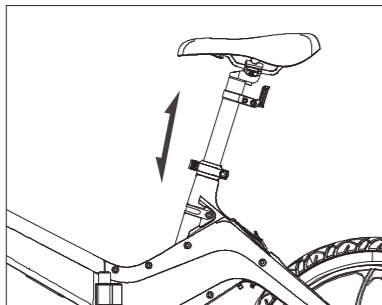

1. When you need to adjust the height of the saddle, first loosen the seat post clamp, then move the seat post to the preferred height, tighten the seat post clamp

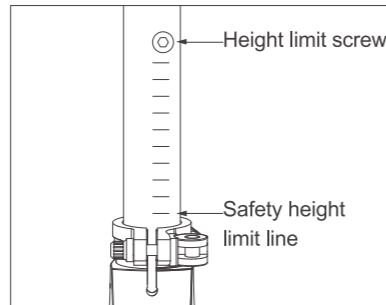

2. The saddle height mustn't exceed the height limit screw or safety height limit line

## Battery and charging

1. Environmental temperature for charging is 0°C-45°C, for discharging is -20°C-60°C, please keep the battery in dry condition
2. Do not put the battery in acidic or alkaline liquid, keep it away from rain, fire, heat and high temperature environment.
3. Do not mis-connect the negative and positive electrodes of the battery; breaking, disassembling and short circuiting the battery are prohibited.
4. Only charge the battery with the original charger of the bike, other charger may cause battery leaking, heating, smoking and in serious situation cause fire and explosion.
5. If the battery is not to be used in a long time, keep the battery in a dry and cool environment, and charge it for 2 hours every two months
6. Charging according to the manual requirements, or else we won't take any responsibilities for the damages occurred
7. Charging in a dry and cool environment, do not charge in closed or high temperature areas
8. Unplug the charger in time when the charging is done, do not plug the charger to power source while not charging
9. When charging, plug the battery first, then connect the power source; When charging finished, disconnect the power source first, then unplug the charger

10. If the charger indicator stops working or the charger overheats and causes funny smell, unplug the charger immediately and repair or replace the charger
11. Keep the charger away from fluids while using and storage, in case of short circuit, avoid any penetrations to the charger
12. Try not to carry the charger around with your bike, if you must, make sure it's well protected and store it in your tool box
13. Try to avoid the battery being fully discharged when using, to keep the battery in good condition and for a longer lifespan, try to only use the bike between battery level 20% to 100%
14. Do not disassemble or replace any parts of the charger by yourself
15. Due to the capacity fade mechanisms of Lithium-Ion battery, the battery capacity will fade at different temperatures, at -10°C the capacity will be 70%, at 0°C the capacity will be 80%, at 20°C the capacity will be 100%
16. Do not put the battery in places that may fall to the ground, in case it may cause battery leakage, over heating that could lead to fire or explosion

# Odometer

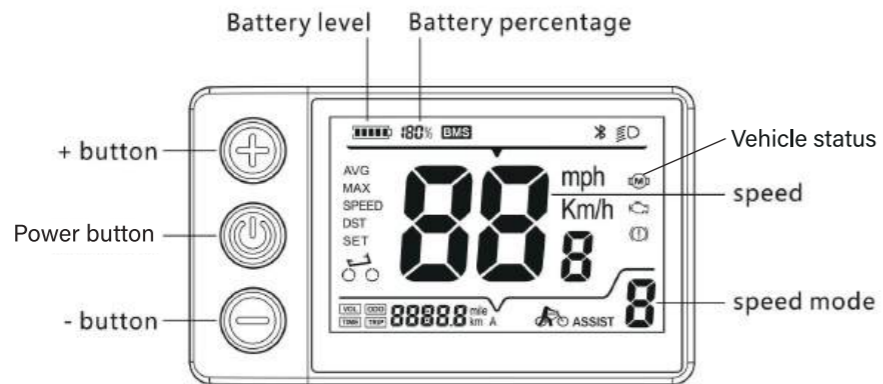

## Button functions:

- M** : Long press to open/close the bicycle. After booting up, press the power button briefly to switch the interface between ODO, TRIP, VOL, and TIME
- +** : After booting up, long press for 3seconds to turn on/off the front light, short press to switch gear
- : After booting up, short press to switch gear

## Speed modes:

- Speed mode 0 : no assistance , pure pedaling mode
- Speed mode 1 : low assistance , top speed 12km/h
- Speed mode 2 : mid assistance , top speed 18km/h
- Speed mode 3 : high assistance , top speed 25km/h

## Icons' meaning:

- Indicates the front light is on
- Indicates the brake is working
- Motor failure
- Equipment failure

**TRIP ODO TIME**  
 Switch among single trip mileage , total mileage and running time  
**88:88.8**  
 The figures of single trip mileage , total mileage and running time

# Quick folding

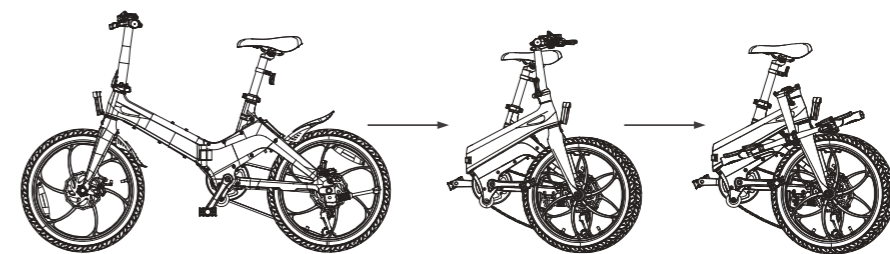

# Hazardous material and contents

Product material	Hazardous materials					
	Lead (Pb)	Mercury (Hg)	Cadmium (Cd)	hexavalent chromium (Cr(VI))	Polybrominated biphenyls (PBB)	Polybrominated diphenyl ethers (PBDE)
Metal	○	○	○	○	○	○
Paint	○	○	○	○	○	○
Plastic	○	○	○	○	○	○
Rubber	○	○	○	○	○	○

This chart is subject to the regulation of SJ/T 1136  
 ○ means the ratio of the hazardous material in the parts is within the GB/T 26572 standard  
 × means the ratio is beyond the GB/T 26572 standard in at least one part

## Charging

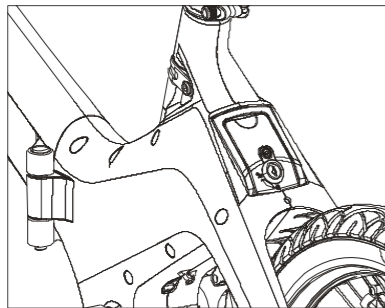

Charging option one : open the rubber cap at the charging port and charge

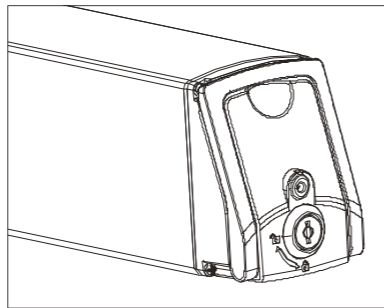

Charging option two : charge the battery outside of the bike , saves you the trouble of moving the bike around

## Strolling and carrying

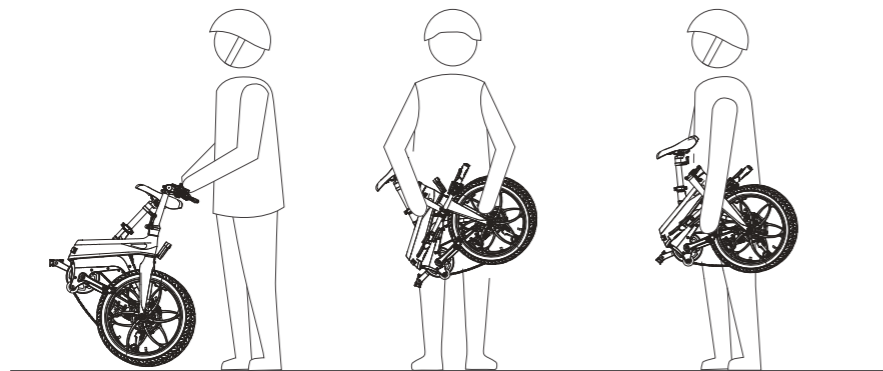

## Safety tips

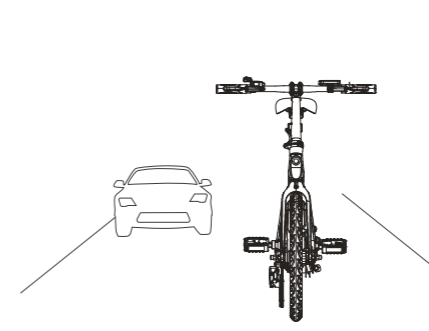

Riding on motorway or other dangerous roads is prohibited

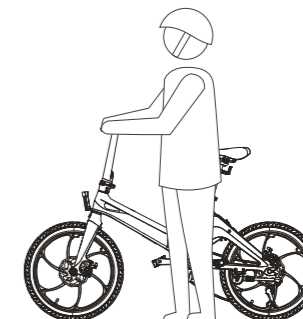

Riding on slippery roads is prohibited

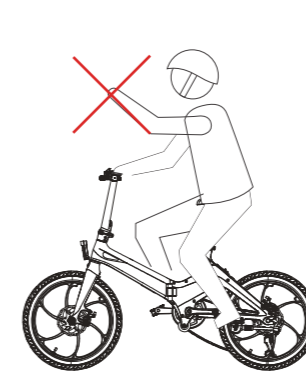

Riding with one hand or no hands on the handlebar is prohibited



Riding on stairways is prohibited